



The Guideline for COIL



Issued : March 2022

The guideline for COIL

Issued: March 2022

POLICY & REGULATION

1. Coil should be loaded in 20' GP container (general purpose container) only.
2. Use 20'FR if the weight of a single coil exceeds 10 tons.
3. The maximum gross mass of the cargo should not exceed payload of container.
4. Coils cannot touch the container floor directly.
5. Proper weight distribution on the container floor.
6. Downward lashings for each coil are necessary.
7. Loop lashing should be arranged on each coil's left and right sides.
8. The weight should be balanced.
9. Coils are not stacked with each other.
10. Wooden bracing between coils is necessary.

PRINCIPLE



Sufficient Dunnage

- Coils can't touch container floor directly, shall use pallets, cradles, or bedding beams under each coil.
- The center of gravity should be in the center of the container and meet the load distribution.
- The cargo mass should be distributed over a sufficient length of the container floor.

Proper lashing and stuffing

- Use blocking, bracing around the coil against the wall and door to avoid movement.
- Blocking/bracing should be used to secure the coil and may be used in combination with lashing gear attached to the anchor points situated on the base structure of the container.

Common sense and notice

- The maximum gross mass (cargo + bedding and securing ('payload') + tare mass of the unit) of the container should not be exceeded.
- Weight over 10 tons/per coil, will not suggest loading in 20' GP container (general purpose container).
- Be balanced. Multiple coils should be positioned to ensure the load distribution.

HOW TO DO

1. Types

Based on the size/weight, there are three types of setting for the coil.

- Eye to side
- Eye to sky
- Eye to rear

Eye: means center of the coil

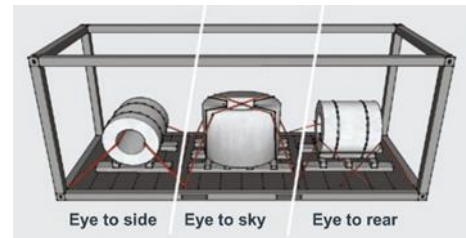

2. More than two coils

One or two coils: the center of gravity should be on the vertical line of the container, the weight should share on the bottom averagely. (Coils with similar weight.)

More than two coils: the weight share on the bottom averagely.

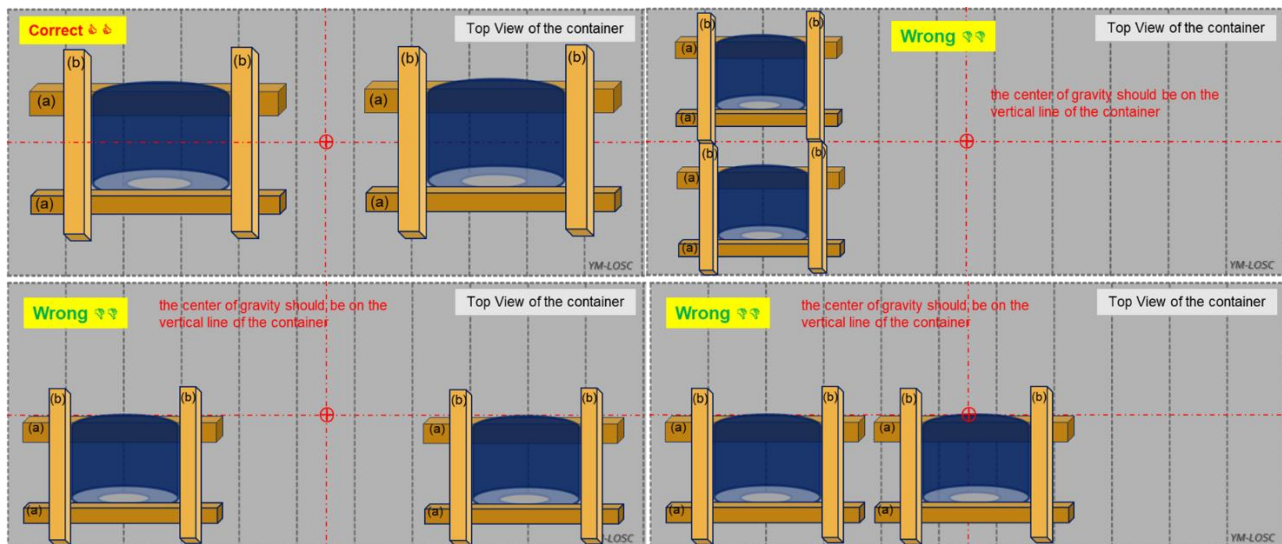

⊕: The symbol means the center of gravity in the container.

3. Use cradle and bedding beams as bedding

- 3.1 The size of the cradle/ bedding beams should be based on the weight and size of the coil.
- 3.2 The bedding beams should be made as a rectangle/square.
- 3.3 The main/bottom bracing (a) should be **vertical with the container bottom cross member**.
- 3.4 Use blocking/bracing around the coil to avoid movement.

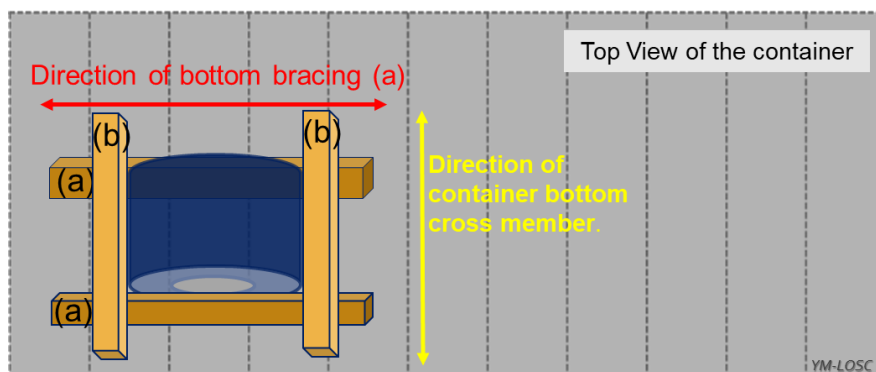

4. Use lashing to secure each coil for moving.

- 4.1 Lashing for each coil is necessary to prevent the coil from moving during transportation.
- 4.2 The lashing direction should be downward (use the lashing ring at the container floor).
- 4.3 The lashing amount for each coil should be both left and right in pairs.

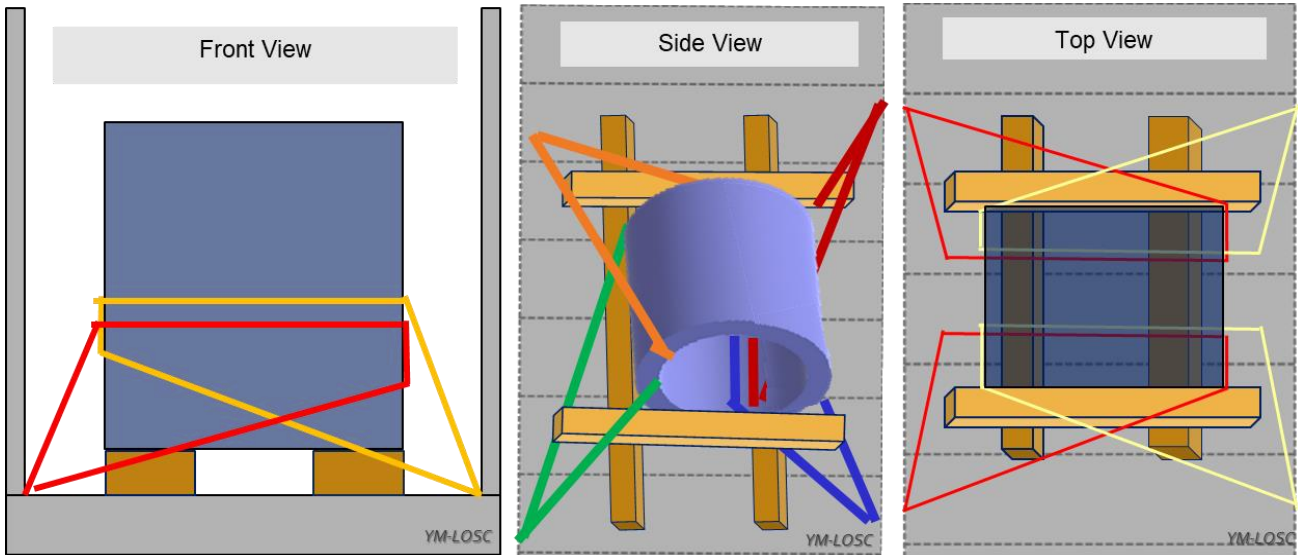

5. Blocking/bracing between side wall & coil

- 5.1 Use bracing between the sidewall and coil to avoid movement during transportation.
- 5.2 The wooden bracing that contacts the sidewall **(c) should be vertical of the container panel.**



- 5.3 **The shape of the wooden frame is similar to “II”** (please refer to below picture (c)(d)(e)(f).
- 5.4 The wooden bracing (c)(d)(e)(f) should be set and extended to the sidewall.

Front view of the bracing

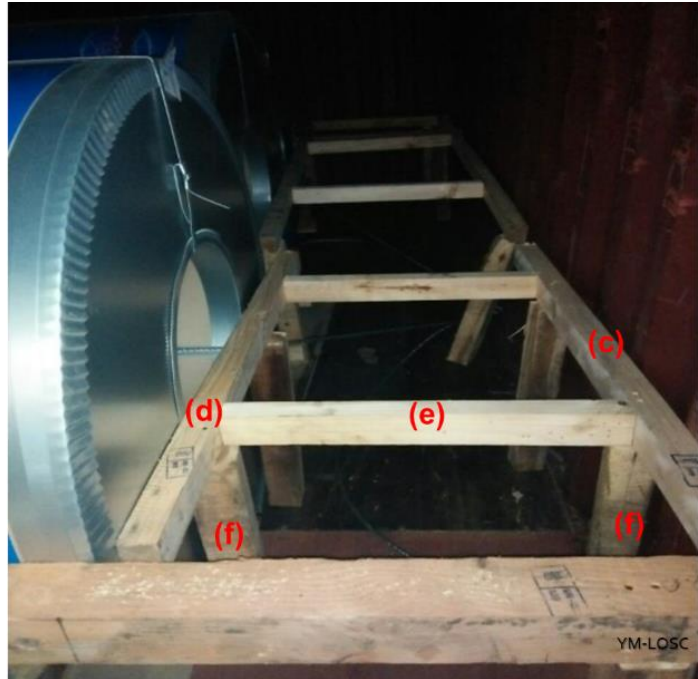
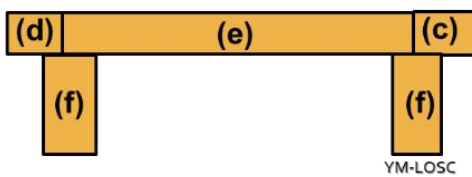

6. Blocking/bracing in front/back of the coil

- 6.1 The strongest structure of the front and rear wall panels is the “corner post” the design is used to bear the weight of the heavy cabinet stack.
- 6.2 **Use the blocking or wooden bracing in front of the end wall to make the bracing contact with the corner post.**
- 6.3 The bracing height should be located at the half height of coil.
- 6.4 For loading two or more coils, wooden bracing between coils is necessary.
- 6.5 It can increase the strength of the front and rear wooden frame, avoiding the coil extrusion caused by the aforementioned during transportation.

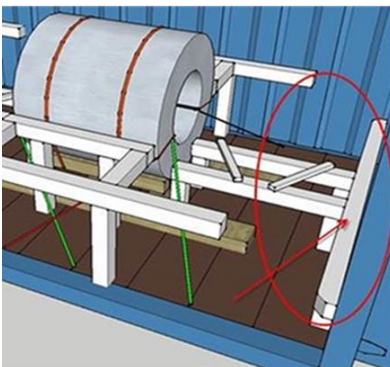

7. Door blocking

- 7.1 When blocking towards the door end, use a bulkhead of adequate dimensions and strength fitted **into the recess** (yellow line) and secure against that.
- 7.2 Ensure that the doors are free from contact with the bulkhead structure.
- 7.3 Wherever possible, fit the bracing battens at the side of the container.

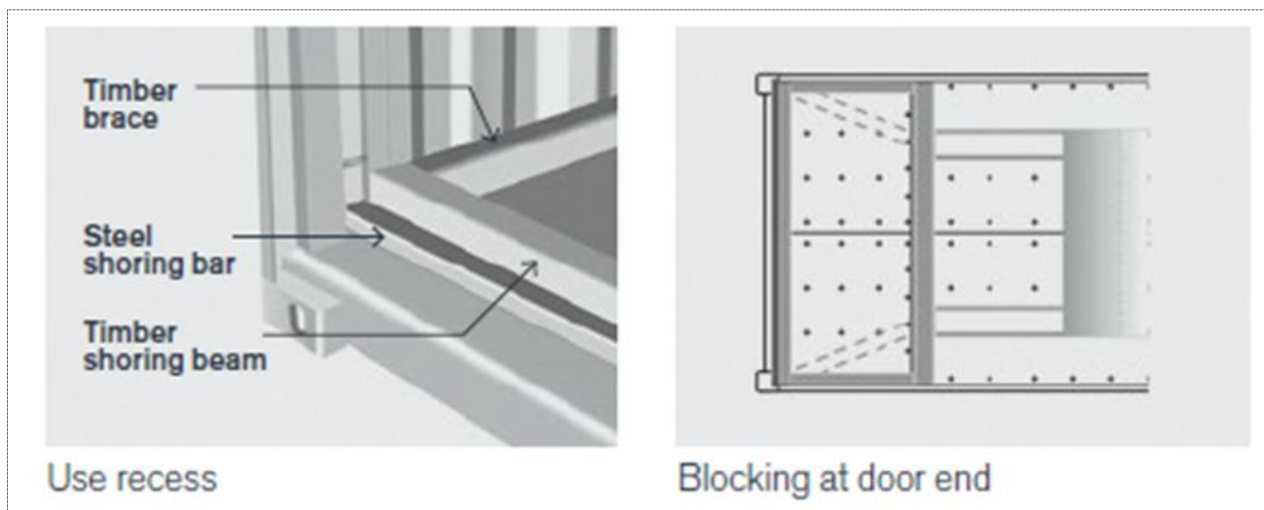

FORMAT OF COIL APPLICATION

- Mail subject: (COIL) Service / Vessel Name-voyage/POL-POD/Refer No.
ex. **(COIL) MD3 / YM WISH 035W /KRPUS-CNSHK/19860404**
- Booking No./Ref No.:
- Vessel name/Voyage:
- POL/POD:
- Type and size of the container to be used:
- Dimension of cargo (each one):
- Weight per coil:
- The number of coils per container:
- Total weight of the cargo (per container):
- Picture of the lashing (including lashing, bracing and coil):

HOW TO GET THE APPROVAL

- Cargo securing pictures should be provided to LOSC three days before vessel ETA.
- Correct mail subject
- All items are fully provided
- Photos are explicit and fit every of our securing/lashing standards.
- Make sure the photos are clear and NO image editing.
- Send the application to the correct PIC: YM-LOSC (losc@yangming.com)

REFERENCE

TT Club (<https://www.ttclub.com/-/media/files/tt-club/stop-loss/stop-loss-13---coiled-materials.pdf>)

CTU Code (https://www.ilo.org/sector/Resources/codes-of-practice-and-guidelines/WCMS_356987/lang--en/index.htm)



YANG MING delivers GOOD for life

No. 271 Ming De 1st Road, Cidu District,
Keelung 20646 Taiwan (R.O.C.)
Tel: 886-2-2455-9988 / Fax: 886-2-2455-9958
<http://www.yangming.com>